

**DULAS Solar Direct Drive
VC88SDD Refrigerator (E003/059)
Installation & Technician's Manual**



Table of Contents

1. COMPONENTS CHECKLIST	3
2. SAFETY INSTRUCTIONS	4
3. YOUR DULAS SOLAR DIRECT DRIVE REFRIGERATOR.....	6
4. REFRIGERATOR COMPONENTS.....	7
5. RECOMMENDED TECHNICIAN'S TOOLS	8
6. MATERIAL SAFETY INFORMATION	9
7. END OF LIFE & PRODUCT RECYCLING	10
8. REFRIGERATOR TRANSPORTATION.....	12
9. PREPARING TO INSTALL	13
10. SOLAR ARRAY ASSEMBLY	14
11. SOLAR ARRAY ORIENTATION.....	20
12. SOLAR ARRAY INSTALLATION.....	21
13. SOLAR MODULE CONNECTIONS.....	23
14. COMMISSIONING SOLAR ARRAY	24
15. ADVICE ON LIGHTNING PROTECTION	25
16. ADVICE ON SURGE PROTECTION.....	25
17. SOLAR ARRAY EARTHING.....	26
18. REFRIGERATOR INSTALLATION.....	27
19. SYSTEM COMMISSIONING	28
20. REFRIGERATOR LOADING	29
21. GREEN COMPRESSOR STATUS LED LIGHT.....	30
22. USER TRAINING.....	31
23. MAINTENANCE TASKS.....	31
24. TROUBLESHOOTING GUIDE	32
25. INSTALLATION & COMMISSIONING RECORD.....	39
26. VC88SDD ELECTRICAL SCHEMATIC	42
27. VC88SDD REFRIGERATION SCHEMATIC.....	43
28. SPARE PARTS.....	43
29. VC88SDD SYSTEM LAYOUT	44

1. Components Checklist

DESCRIPTION	QUANTITY
REFRIGERATOR	
VC88SDD Refrigerator Cabinet	1
Refrigerator Baskets	4
Refrigerator Key	2
SOLAR ARRAY	
315W min Solar Modules	2
20m Pre-terminated Solar Cable (+ve & -ve)	1 pair
Solar Connector – Branch Plug	1
Solar Connector – Branch Socket	1
Earthing Kit (incl. Earth Rod, 25m Earth Cable & Earth Clamp)	1
MOUNTING SYSTEM (see page 14 for references A to G)	
(A) End Clamp 28-33mm Set	4
(B) Mid Clamp 28-42mm Set	2
(C) Front fixed leg	2
(D) C-Rail 47-3 – 1530mm	2
(E) C-Rail 47-3 - 750mm	2
(F) Rear adjustable leg	2
(G) Rail connector set 47	2
Coachscrews, Rawlbolts, Washers	2 packs
Screws	1 pack
Wall Plugs	1 pack
Cable Ties	1 pack
Cable Tie Bases	1 pack
Silicon Sealant	1

2. Safety Instructions



Read the Manual - please read all instructions completely before installing. Installation and system servicing should only be carried out by a qualified and competent engineer. Work performed by persons with insufficient technical knowledge may adversely affect the performance of the unit or cause physical injury or damage to the equipment.



The refrigerator is not to be used by persons (including children) with reduced physical, sensory or mental capabilities, or lack of experience and knowledge, unless they have been given supervision or instruction. Children must be supervised not to play with the appliance. This refrigerator is for professional use only. It is not designed for household use.

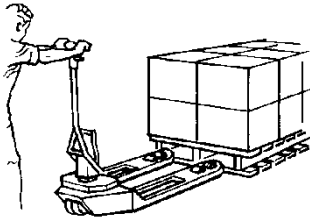

Refrigerator and power system are heavy - please observe good manual handling procedures when moving the refrigerator and solar power system. Only use suitable transport equipment.



Safe working - Please observe safe working at height practices when installing the solar array.



Live electrical components – solar modules are live when exposed to sunlight. Isolate the array (using the PV isolator on the back of the refrigerator) before disconnecting any components.



Electrical danger – under fault conditions high electrical currents can occur. Never bypass a circuit breaker and always replace with the same type and rating.

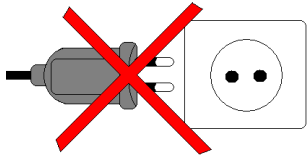

DC power only - this refrigerator is designed for operation with the solar power system supplied. Do not connect the refrigerator to other power supplies.



Dangerous substances - this refrigerator contains substances that are not biodegradable and can cause harm, please ensure that all components of the refrigerator are disposed of correctly, see page 8 for more information. Do not damage the internal side panels of the compartment.



Keep Dry – This refrigerator is for indoor use only. Do not expose it to rain.

WARNING: This unit's cooling system contains flammable refrigerant. Due to this fact, the following information is particularly important:

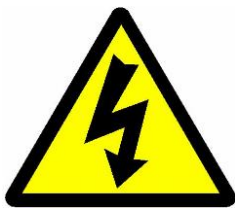

Warning: Do not damage the refrigeration circuit. Ensure that sharp or pointed objects do not come into contact with the refrigeration circuit.

Warning: Do not use mechanical devices or other means to accelerate the defrosting process, other than those recommended by the manufacturer.



Warning: Keep ventilation openings, in the appliance enclosure or in the built-in structure, clear of obstruction.

Warning: Do not use electrical equipment inside the appliance.

Warning: Do not store explosive substances such as aerosol cans with a flammable propellant inside this appliance.

3. Your Dulas Solar Direct Drive Refrigerator.

Congratulations on choosing the Dulas VC88SDD vaccine refrigerator. With over 30 years of engineering experience in the production of solar powered vaccine refrigerators, Dulas is considered one of the market leaders in this field.

The VC88SDD is Dulas' latest innovation in solar refrigeration. Using our new solar direct drive technology we have replaced the traditional battery energy store with a ground breaking phase change solution. With this new technology we can offer the same renown Dulas quality and reliability that have always kept your vaccines safe, but in a simpler and more efficient package.

How does solar direct drive work?

When the sun shines the solar panels generate electricity which directly drives the refrigerators compressor, cooling down the refrigerator and its contents. As a result the compressor only operates during the day. To maintain the temperature at night or when the sun is not shining the refrigerator has a phase change lining. This interior lining holds the exact temperatures required for safe vaccine storage and acts as a "cold store", storing energy that keeps the temperatures stable all day and night.

In order to store sufficient energy to keep vaccines safe for prolonged periods without any sunshine, the refrigerator must be allowed time to charge it's cold store. Under normal sunlight conditions (8 hours/day of solar irradiance >200W/m²) the refrigerator will take approximately 7 days to fully charge the cold store and be ready for vaccine storage.

Recommended solar array

The VC88SDD has been designed to meet the World Health Organisation's Performance, Quality & Safety (PQS) standards. The refrigerator has been independently tested to the PQS standard WHO/PQS/E03/RF05 and is a Hot zone rated appliance with an ambient operating temperature range of between +5C and +43C. For use in such Hot Zone environments it should be powered by a minimum 400 peak Watt (Wp) solar array with an open circuit voltage (VOC) not exceeding 45Vdc.

4. Refrigerator Components

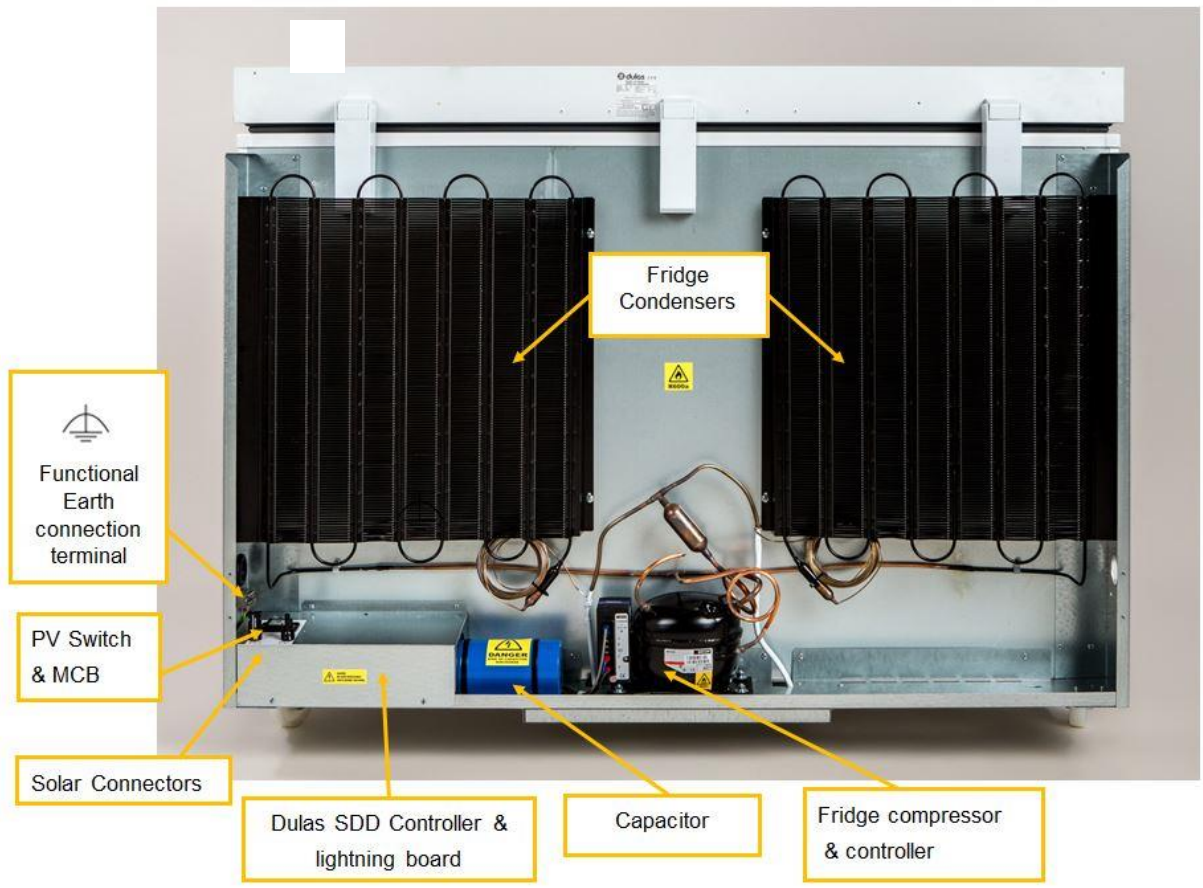
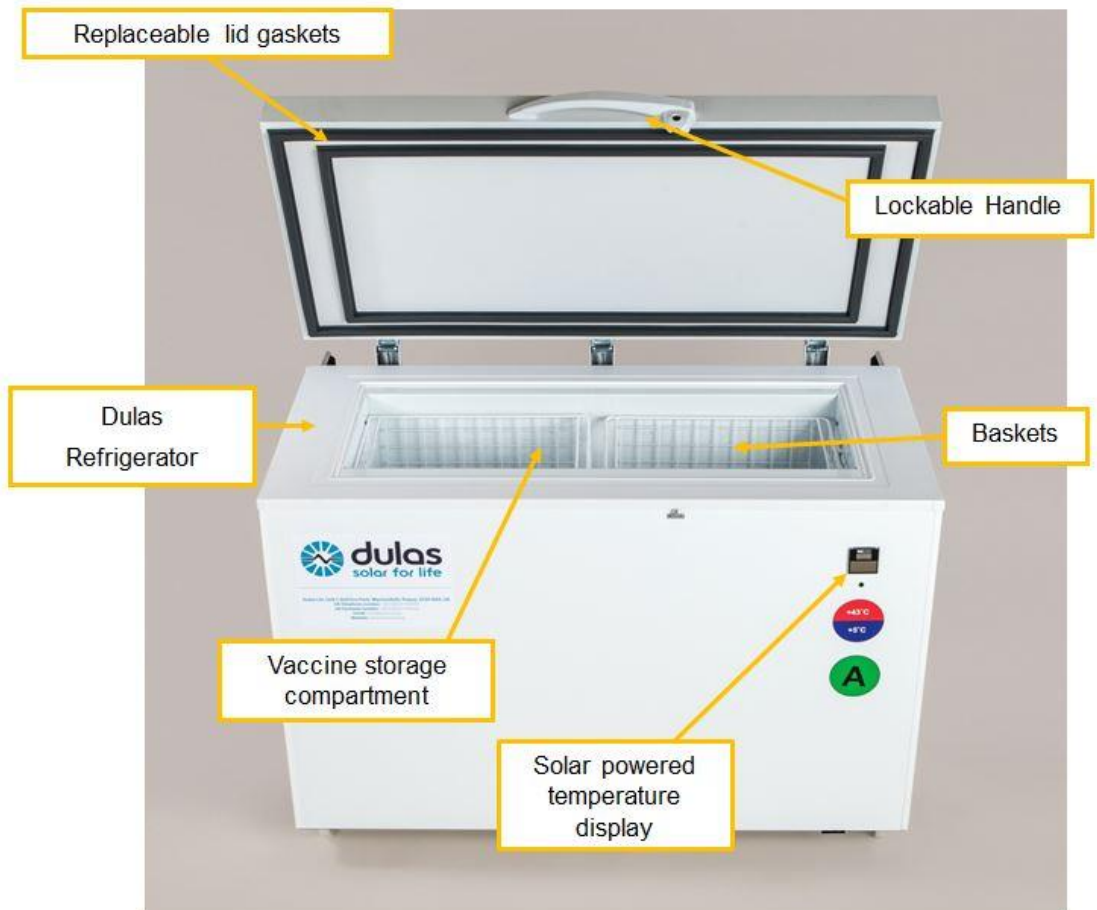

5. Recommended Technician's Tools

Pozidrive No.2 Screwdriver

Small Slot-head Screwdriver

Pliers

Wire Cutters

Craft Knife

Drill and Bits

Hammer and Punch

Deep reach 18mm socket (supplied)

Torx T30 key (supplied)

Torx T45 key (supplied)

Ratchet socket handle (not supplied)

Adjustable Spanner

Multimeter (20A rated)

Tape measure

Spirit level

Compass (supplied)

6. Material Safety Information

THE REFRIGERATOR

The Dulas VC88SDD conforms to the European directive 2002/95/EC on hazardous substances and does not contain the following elements: lead, cadmium, mercury, hexavalent chrome, PBB or PBDE.

The absence of ozone destroying materials is in accordance with EC 1005/2009 (CFC-free)

It is compliant with European Standards (CE) EN60335-1:2010 & EN60335-2-24:2010.

R600a refrigerant – Isobutane, is highly flammable when mixed with air. Do not inhale, ingest, and avoid contact to skin. Ensure that any work carried out on the refrigeration circuit is done by a competent refrigeration engineer.

THE PHASE CHANGE MATERIAL (PCM)

The refrigerator contains an organic phase change material (PCM) that provides the energy store for the refrigerator. This PCM material is a paraffin wax that is liquid at room temperature and is stored in large tanks secured inside the walls of the refrigerator. In normal use the user will never be aware of its presence. This PCM is classified under regulation (EC) No 1272/2008 as a category 1 aspiration hazard and is classified under regulation 67/548/EWG, 1999/45/EG as having the potential to cause physical harm (R65 & R66). At normal ambient temperatures this product will be unlikely to present an inhalation hazard because of its low volatility. At high temperature aerosol/mist can cause an irritation of the respiratory tract.



H304 May be fatal if swallowed and enters airways.

P301 + P310 IF SWALLOWED: Immediately call a POISON CENTRE or physician.



P331 DO NOT induce vomiting.

R65: Harmful: may cause lung damage if swallowed.

R65: Repeated exposure may cause skin dryness or cracking.

In the event of a PCM spillage:

- Wear suitable protective clothing, gloves and safety glasses when clearing up spillages.
- Use an absorbent substance such as sand to contain any escaping material.
- If the PCM contaminates rivers and lakes or sewers inform respective authorities. Avoid water ingress underground. Do not flush into surface water or sanitary sewer system.

7. End of Life & Product Recycling

PACKAGING

The packaging is made from recyclable / reusable materials and should be brought to an official recycling centre. The materials used are:

- Heat treated (HT) timber, certified by UK Forestry Commission (ISPM No. 15 Mark)
- Corrugated cardboard / Cardboard
- Polyethylene plastic
- Moulded polystyrene parts
- Steel reinforcing straps

WARNING – Keep packaging away from children - danger of suffocation from plastic!

WORN OUT REFRIGERATOR

The refrigerator still contains valuable materials and is not to be disposed of in the normal household waste.

- Ensure that the cooling circuit of the worn out device is not damaged when being transported.
- Information on the coolant used is on the type plate on the back of the refrigerator.
- The walls of the refrigerator contain an organic phase change material that can be harmful and must be disposed of safely. Please contact Dulas for advice.
- Worn out devices must be professionally disposed of in accordance with local regulations and legislation.

Potentially hazardous components / materials are:

- Refrigerant gas (R600a)
- Phase change material (PCM) - paraffins, normal C5-20
- Electrolytic capacitor
- Electronic components – SDD controller
Compressor controller
Refrigerator compartment temperature display

Disposal of Phase Change Material (PCM)

The PCM used in the Dulas refrigerator has a very long life and does not degrade through use. At the end of the refrigerators useful life the PCM should be either recycled or disposed of in accordance with applicable regional, national and local laws and regulations. Contact your local waste disposal authority for advice. The product can be incinerated in accordance with local regulations. In the EU it has a Waste Disposal Code (EWC): *13 08 99 oil waste not otherwise specified*.

SOLAR POWER SUPPLY

Do not dispose of this equipment with normal domestic waste!

To comply with the European Directive 2002/96/EC on Waste Electrical and Electronic Equipment and its implementation as national law, electrical equipment that has reached the end of its life must be collected separately and returned to an approved recycling facility. Any device that you no longer require must be returned to our agent, or find out about the approved collection and recycling facilities in your area.

Ignoring this European Directive may have potentially adverse effects on the environment and your health!

Solar modules contain materials that can be recovered and reused in either new PV modules or other new products. Industrial recycling processes exist for both thin-film and silicon modules. Materials such as glass, aluminium, as well as a variety of semiconductor materials, are valuable when recovered.

8. Refrigerator Transportation

To reduce the risk of bodily injury, or damage to the refrigerator, the following precautions **must** be observed:

- Properly secure the refrigerator when in transit to prevent it moving or falling within the vehicle.
- Plan any lifting or moving of the refrigerator in advance, paying particular attention to steps, gradients and doorways.
- Ensure suitable moving and lifting equipment is used as required.
- Make sure there is sufficient assistance to safely carry out any lifting and moving of the refrigerator.
- Keep the refrigerator in its original packaging for as long as is practical to prevent damage during transit and unloading.
- Do not drop the refrigerator or allow it to topple over.



9. Preparing to Install

Before starting the installation please read through the complete installation manual. By taking the time to follow these simple instructions the whole installation process will be much easier.

- 1) Carefully unpack the system and check that all components are present, familiarise yourself with them and make sure that everything has been identified. Ensure that you have all tools required to complete the installation.
- 2) Familiarise yourself with the Dulas Installation Record in Section 24 of this manual. This provides a step-by-step guide to the installation process and also gives you a formal record of the installation.
- 3) Discuss and decide a position for the refrigerator, ensuring that it is out of direct sunlight and in a well-ventilated, dry place. The cooler the room, the better the performance. **Note: avoid locations where room temperature may fall below +5°C.**
- 4) Identify a safe position for the solar array, ensuring that it faces the correct direction and is mounted at the correct tilt angle for the system location. **Ensure that the solar array is not, and will not become, shaded in the future and that it is accessible for cleaning and maintenance.**
- 5) Work out the best route for the solar array output cable and the earthing cable, ensuring that there is sufficient length to reach the refrigerator and that our advice on lightning protection is followed (see Section 14).

Each component should have a sensible, well thought out, **safe** location, allowing access for routine maintenance.

10. Solar Array Assembly

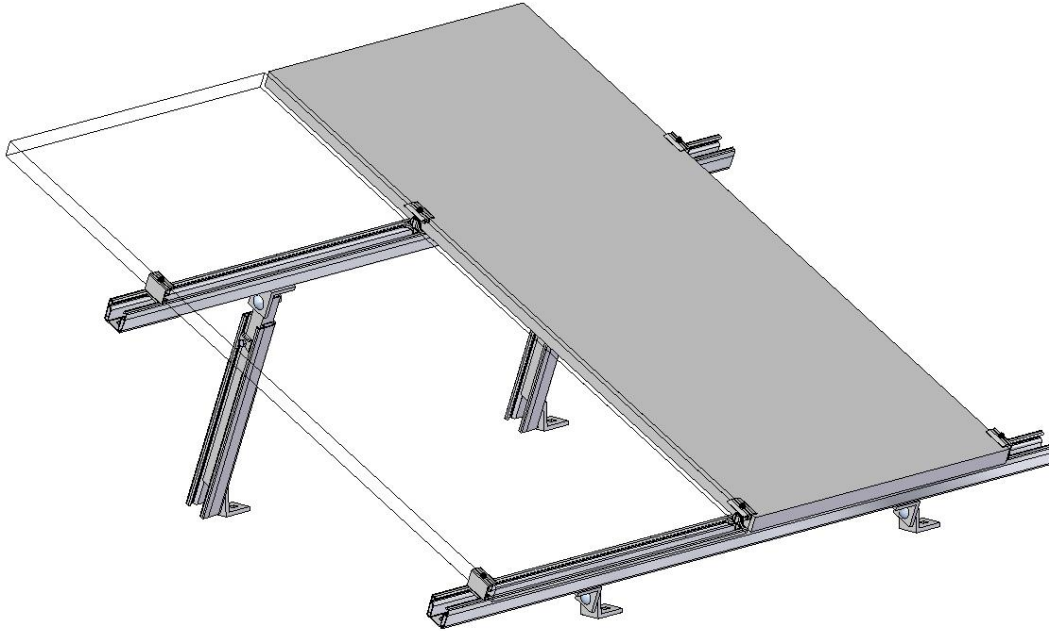

WORKING AT HEIGHT IS DANGEROUS – PLEASE OBSERVE SAFE WORKING PRACTICES

FRAGILE ROOFS – ENSURE THE ROOF WILL HOLD YOUR WEIGHT PLUS THAT OF THE ARRAY BEFORE YOU CLIMB ONTO IT

SOLAR PANELS ARE FRAGILE - BROKEN MODULES CANNOT BE USED: TAKE CARE NOT TO DROP TOOLS OR LEAN ON THE MODULES WHILE WORKING ON THEM.

PLEASE READ ALL OF THE INSTRUCTIONS THOROUGHLY BEFORE COMMENCING

These instructions apply to all variants of the Dulas mounting system: 2 and 3 module systems in both portrait and landscape orientation.

Tools required to assemble the mounting structure:

- Deep reach 18mm socket (supplied)
- Torx T30 key (supplied)
- Torx T45 key (supplied)
- Ratchet socket handle (not supplied)

If this is your first time installing the Dulas mounting system it is highly recommended to do a test assembly at ground level prior to working on the roof top. This will ensure you are familiar with how the system goes together and can work out any problems in a safe environment.

The mounting system is supplied in pre-assembled parts. See below for a pictorial guide to identifying these individual parts (refer to the parts list in Section 1 for the exact quantity of parts you should have)

Mounting system components for 2 module systems

A) End clamps x 4

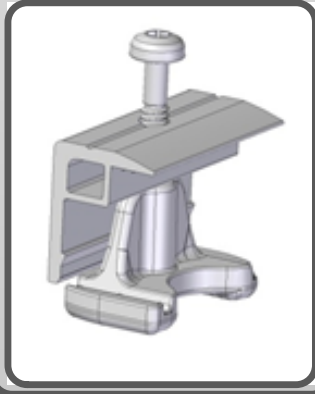

B) Mid clamps x 2



C) Front fixed leg x 2

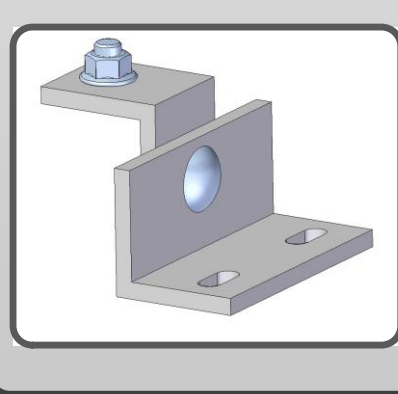

D) 1530mm rail x 2

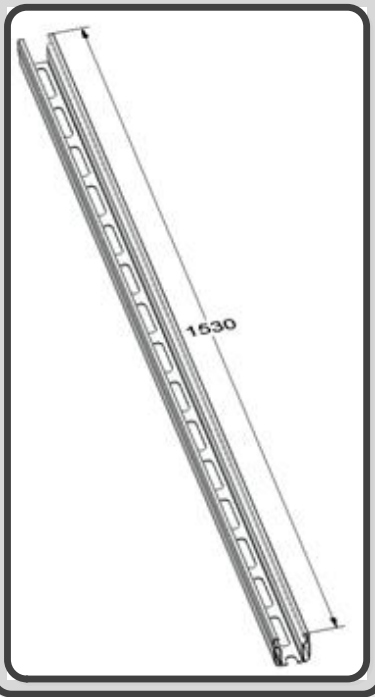

E) 750mm rail x 2

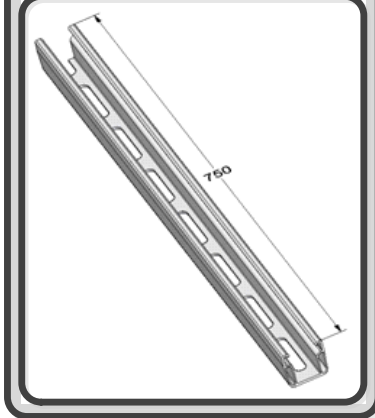

G) Rail connector x 2

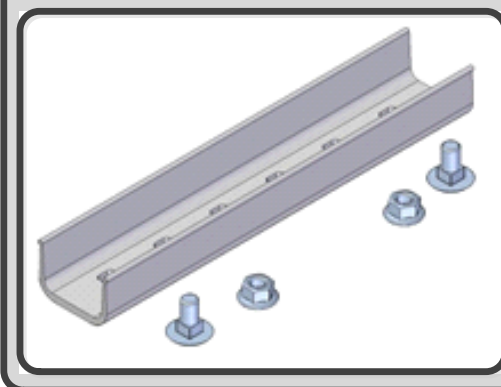

F) Rear adjustable leg x 2

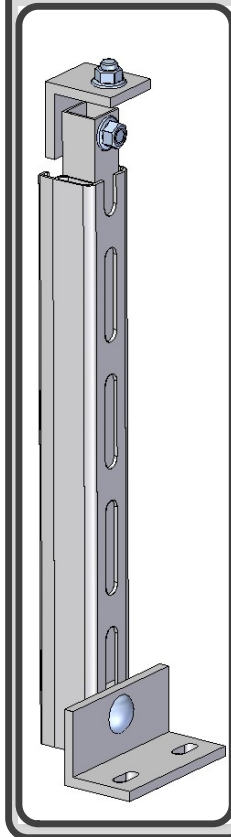

The mounting system can be assembled to allow the modules to be attached in either portrait or landscape configuration. The decision between which option to use is usually guided by which direction the joists run on your roof.

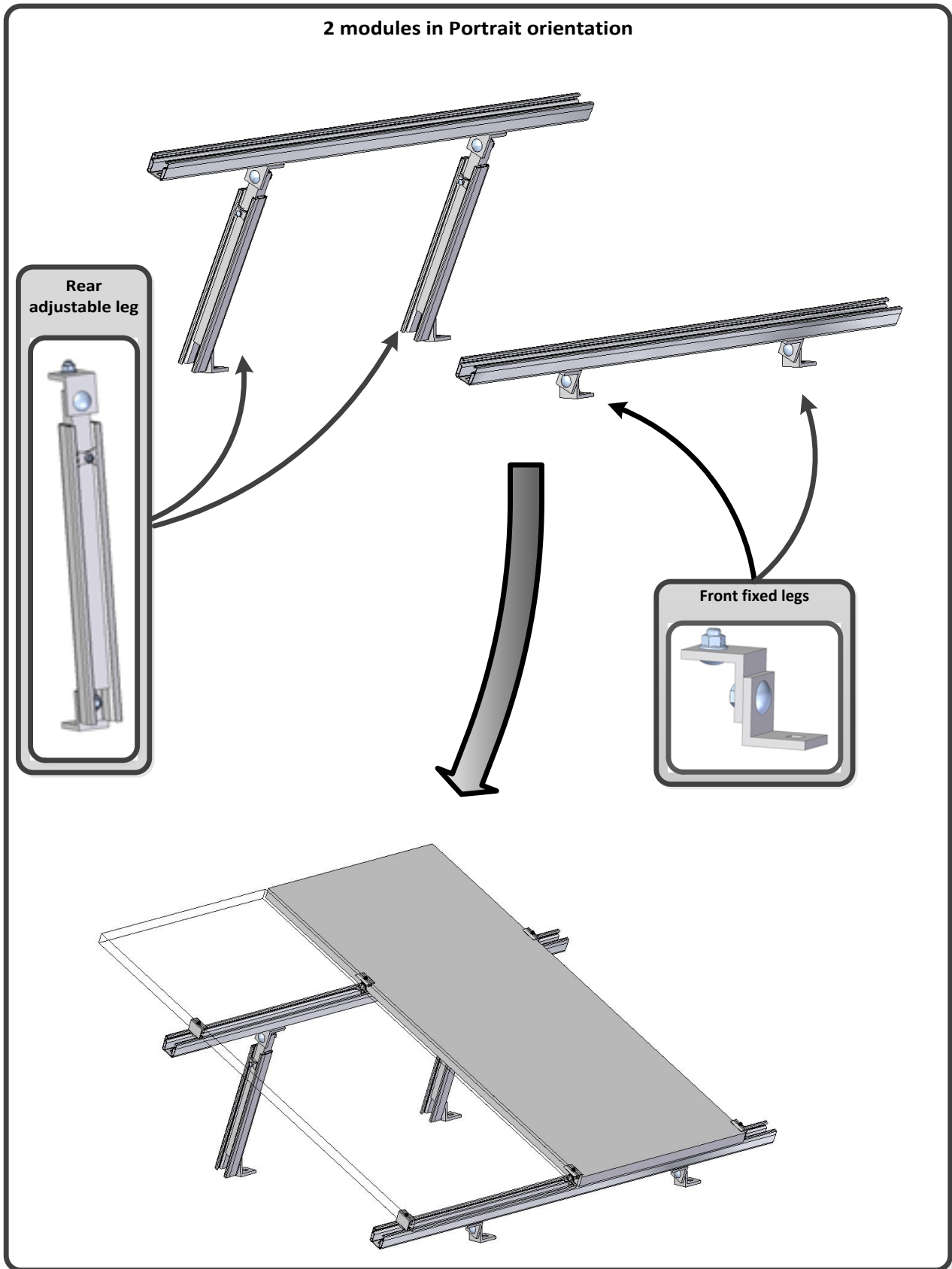

2 modules in Landscape orientation

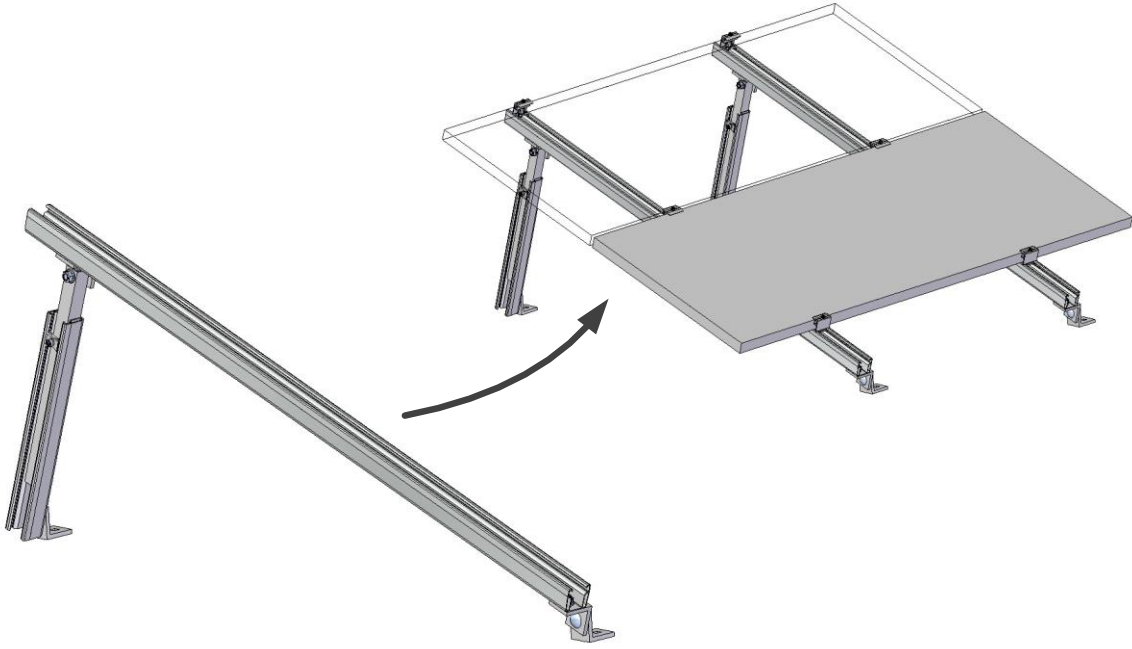

Attaching solar panels to the rails

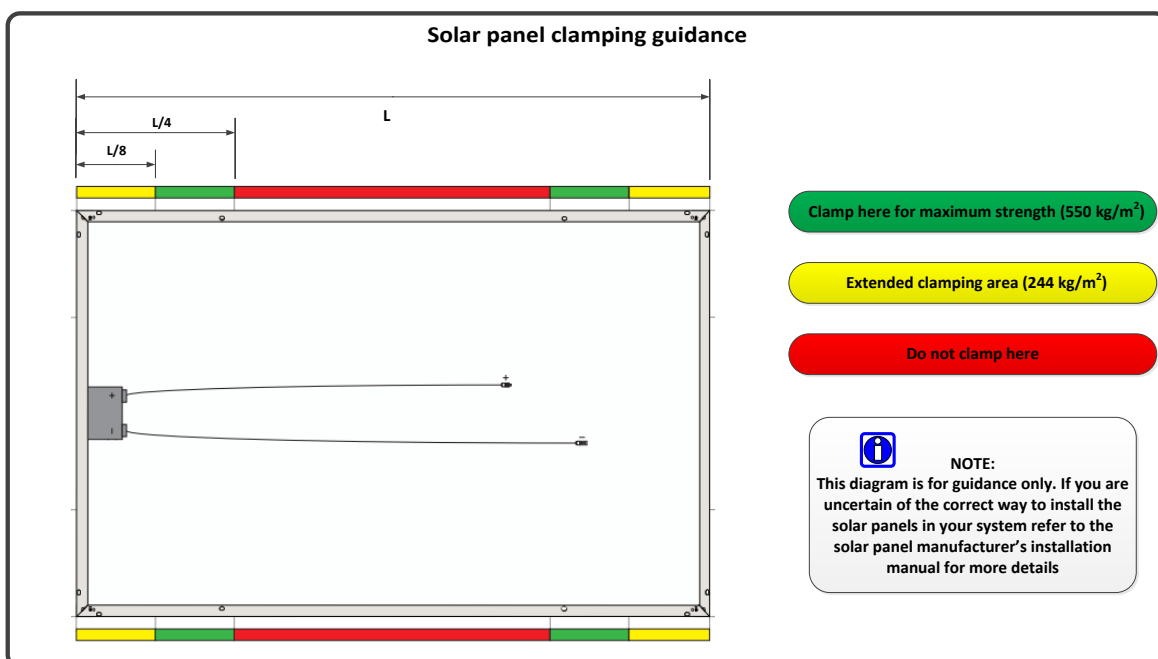
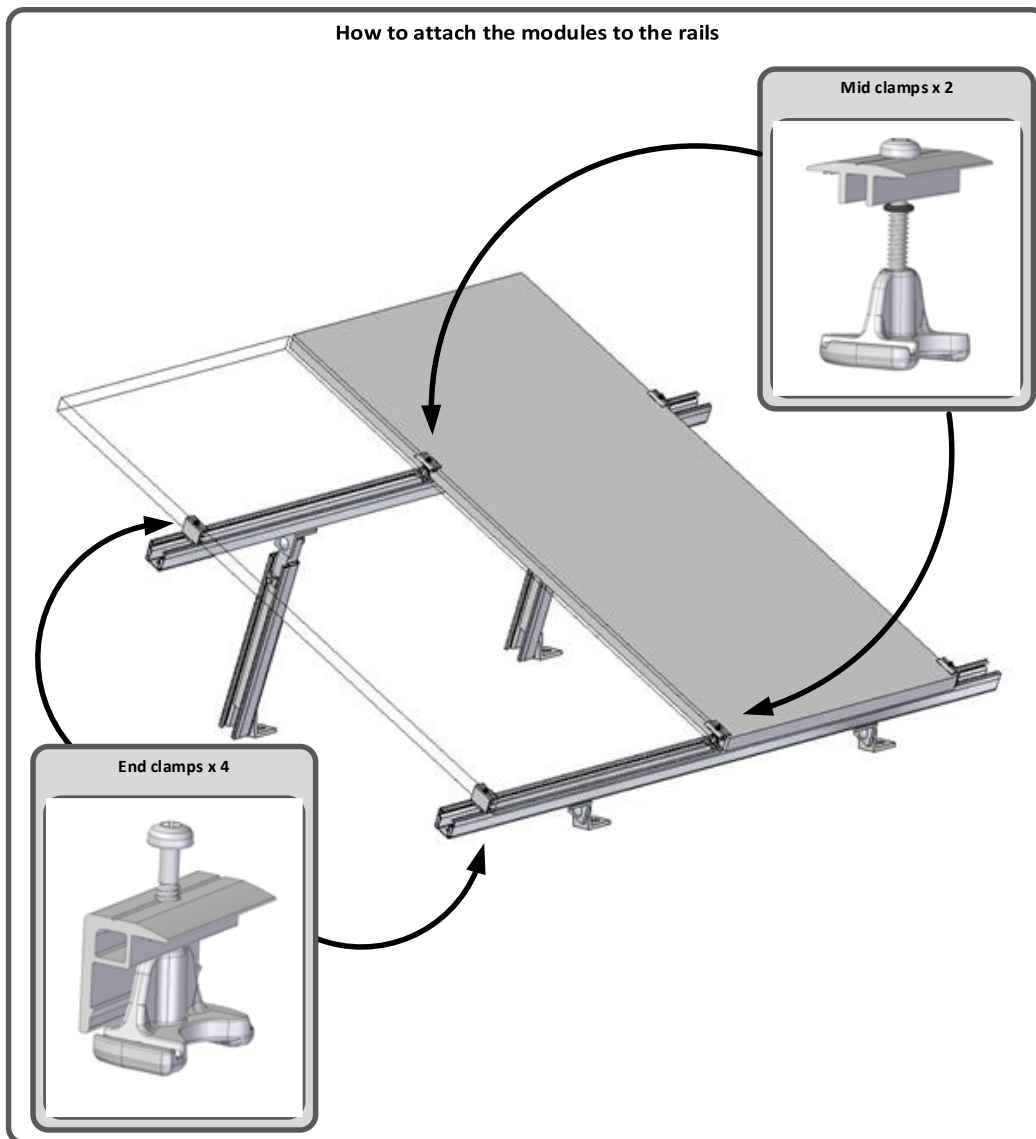

In order to minimise the shipping volume some systems have the rails supplied in two pieces. In this case we also provide a rail connector to securely attach the two rail sections together:

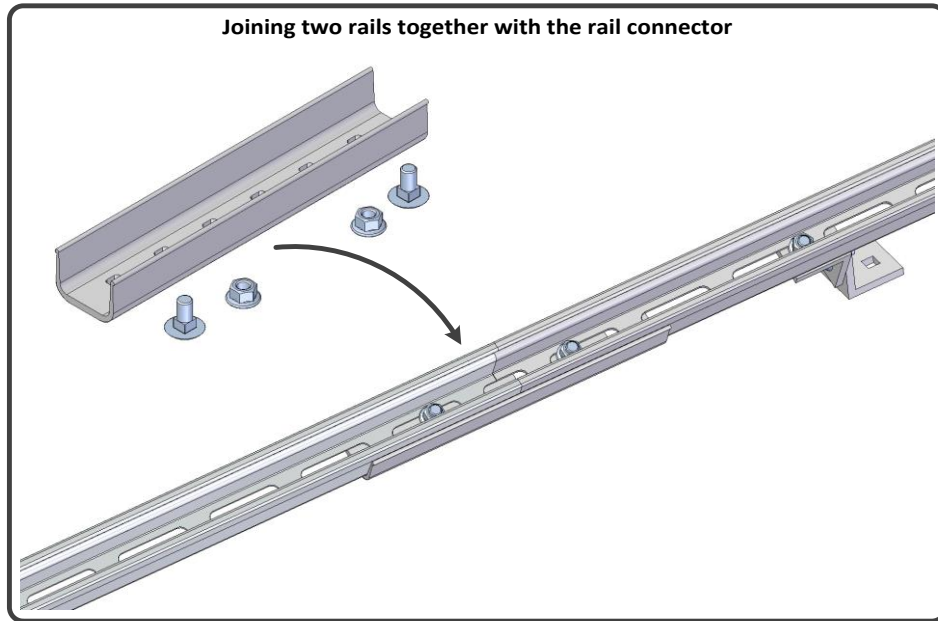

Large arrays are supplied with three front legs and three back legs. The outer two should be positioned as described previously but the third leg should be positioned approximately in the middle of the rail.

The mounting system is made from aluminium and is adaptable to a wide variety of mounting options. If your mounting area cannot be level e.g. you have a sloping roof, then the correct angle must be made by adjusting the position of the mounting feet and the leg lengths.

11. Solar Array Orientation

The solar array must be permanently positioned where the modules will receive the maximum amount of sunshine. A suitable position must be found away from trees and tall objects, to avoid shading the array, as this will impair the performance of the modules. Remember that the modules are very fragile and should not be located where they may be damaged.

Please ensure that the support structure is:

- **SECURE AND NOT TWISTED**
- **ACCESSIBLE FOR CLEANING**
- **WELL VENTILATED**
- **SAFE FROM SEVERE WEATHER CONDITIONS**
- **NOT SHADED (BETWEEN 7 am & 5 pm)**

The solar array should face towards the equator – i.e. South in the Northern Hemisphere, North in the Southern Hemisphere.

Use the compass provided with the refrigerator to ensure the array is facing the correct direction.

The tilt angle of a solar array is dependent on the country in which it is located. The front of the solar modules must be cleaned every week or when necessary in dusty areas.

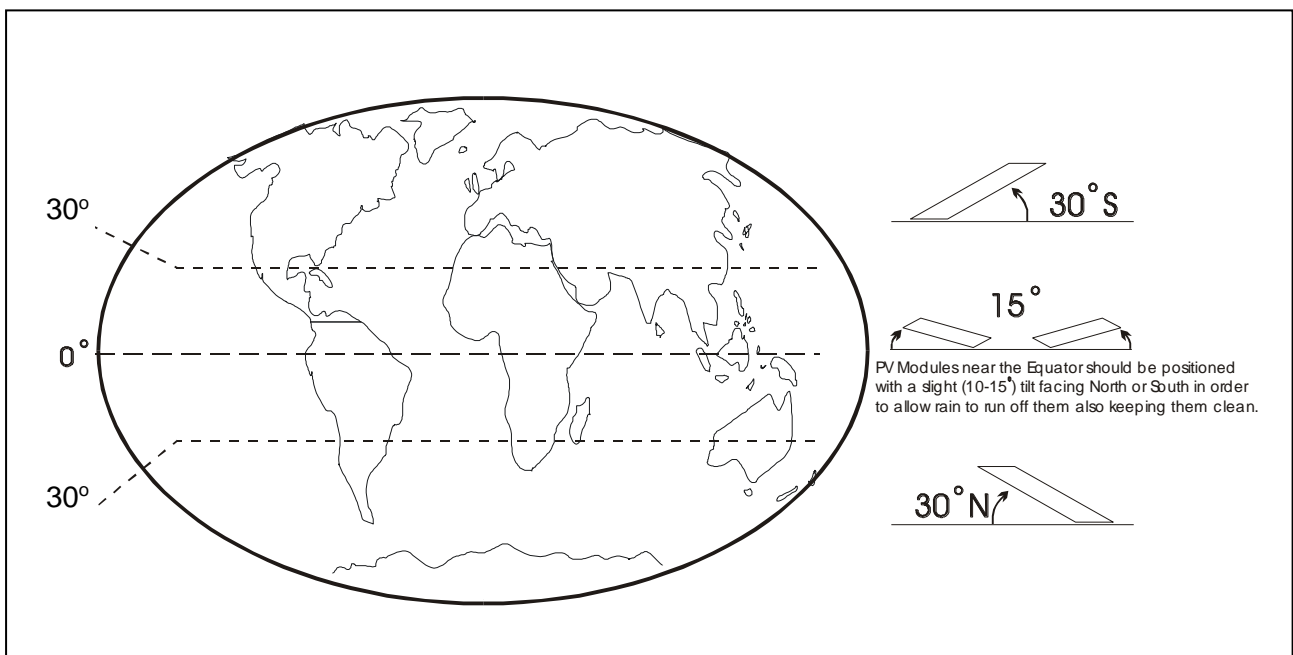

12. Solar Array Installation

Attention – Only connect the Dulas Solar Direct Drive refrigerator to the solar array supplied. Connection to other solar power systems may damage the refrigerator or cause it to not function correctly.

The solar array must be permanently located in a safe and unshaded position, orientated to face the equator to guarantee maximum energy generation. A compass has been supplied to assist with optimum positioning.

The final country of location will dictate the optimal tilt angle at which to install the solar array. The tilt angle should be equal to the locations latitude to a minimum of 10°. The minimum 10° tilt ensures that rain will help to clean the modules.

For example:

Latitude = 15°

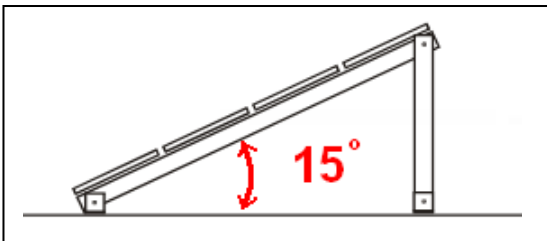

Latitude = 5°

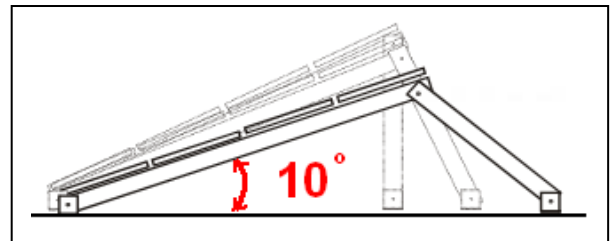

The mounting system is made from aluminium and is adaptable to a wide variety of mounting options. If your mounting area cannot be level e.g. you have a sloping roof, then the correct angle must be made by adjusting the position of the mounting feet and the leg lengths.

Please ensure that the supporting structure (i.e. roof) can support the weight of the array and that the fixings sufficiently penetrate a solid sub-structure. Simply screwing the mounting system to roof decking is not adequate to withstand high wind loads.

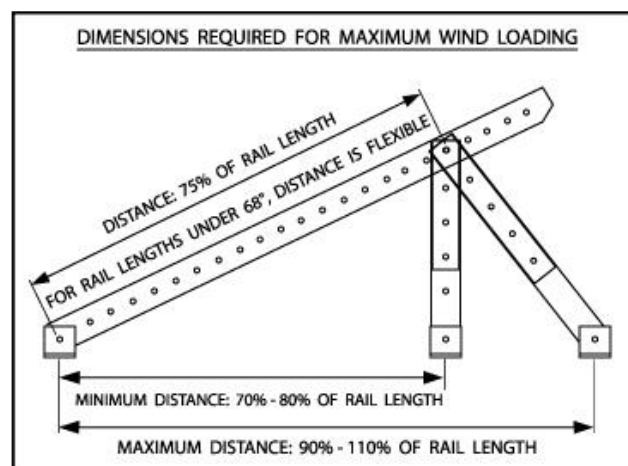

Following the guidance in sections 10 and 11 above, determine the required tilt angle for the array. Use an inclinometer (or free smart phone app e.g. “Angle Meter” in the Google Play store) to set the array tilt. Alternatively a triangle may be cut from a piece of card and used with a spirit level to set the array angle correctly. Refer to the table below for the dimensions necessary to produce a triangle of the correct size.

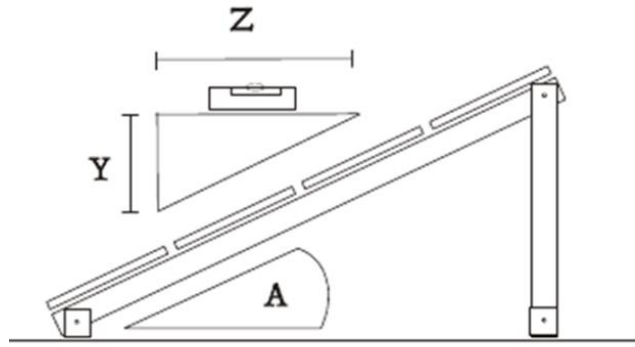

Required Angle (A)	Length of Y	Length of Z	Required Angle (A)	Length of Y	Length of Z
10°	9cm	50cm	30°	29cm	50cm
15°	16cm	60cm	35°	35cm	50cm
20°	22cm	60cm	40°	42cm	50cm
25°	28cm	60cm	45°	50cm	50cm



13. Solar Module Connections

Please ensure that the solar modules are connected in parallel as per the diagram below. ***Incorrect connection of the solar array could cause permanent damage to the refrigerator and its components.***

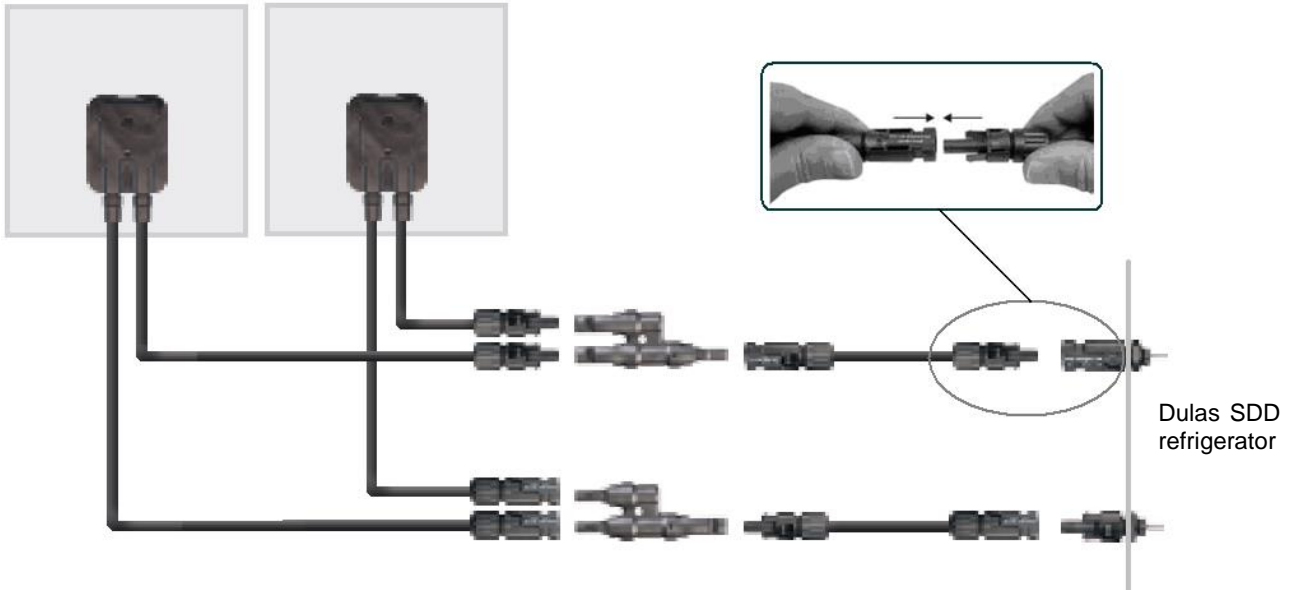

Only use the solar cable and solar connectors provided. Follow good electrical installation practices when installing the cables:

- Route the cables where they cannot be damaged or subjected to excessive heat.
- Do not install the cable around tight bends.
- Ensure that the cable is supported along the full length of its route to the refrigerator, using the cable ties and bases supplied.

Use the supplied length of conduit to protect the solar array cables as they enter the building or as it passes over sharp edges. The conduit is slit so that it can be easily clipped over both cables. Once on, cable tie it in place and if necessary fill the external end with the supplied silicon sealant to seal the hole.



DO NOT DISCONNECT THE SOLAR CONNECTORS UNDER LOAD.

If you need to disconnect any of the solar connectors (at the solar array or at the refrigerator) please ensure that the refrigerator has been **turned off** at the PV switch (located at the back of the refrigerator) **before** disconnecting.

Using the tool provided (or your fingers) squeeze the catches of the adjoining solar connector allowing you to pull the PV connectors apart. Do not use inappropriate tools to disconnect the solar connectors as this may cause permanent damage and an electrical hazard.



14. Commissioning Solar array

To confirm that the solar array is properly connected and working to its full capacity carry out the following steps in strong sunshine:

1. Measure the Short Circuit Current (Isc) of the individual solar panels before connecting them together. You should measure approximately 9A per solar panel (refer to PV module data label for the exact value).
2. Connect the panel(s) together and connect them to the solar array output cable.
3. Cover the solar panel(s) with either cardboard or a thick blanket and ensure they remain covered for the duration of the commissioning.
4. Uncover **one panel only** and measure the Isc at the end of the array cable. It should be equal to the Isc of a single panel.
5. Cover up the first panel and uncover the second panel. Repeat the Isc measurement at the end of the array cable.
6. Continue until all the panels have been tested in this way and you have confirmed the integrity of the array cabling.

Alternatively, if you have a DC clamp meter then you can measure the full array Isc directly by joining the ends of the array cable together and measuring the current in the cable.

15. Advice on Lightning Protection

In order to reduce the risk of damage from a lightning strike on any part of the system, please take note of the following information:

- Keep all cable routes as short and straight as possible.
- If an existing lightning protection system is present please bond the array directly to this and check whether the Dulas array earthing kit supplied is required.
- Keep the solar cable and earthing cable separate by at least 1.5 metres.

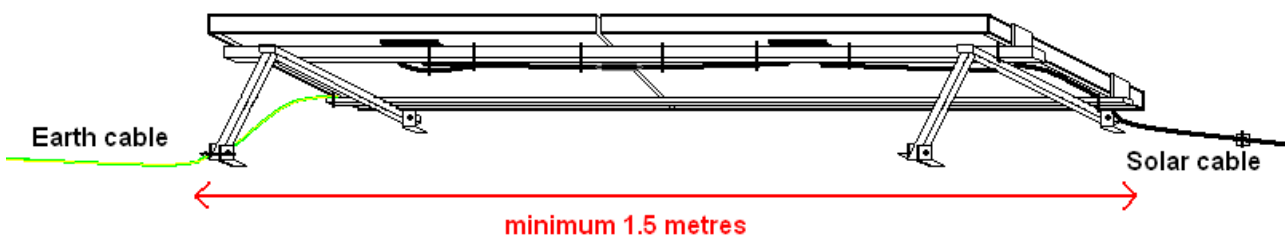

Ensure that all fastenings on the array earthing kit are secure and check them every year.

For a Solar Direct Drive installation where the refrigerator is directly connected to the solar array it is important to also connect the refrigerator cabinet to earth. This protects the equipment and any people who may be touching the refrigerator from electric shock during fault conditions. Dulas SDD cabinets have a dedicated earthing block on the rear of the cabinet for this purpose (see Section 4). This earth block can be connected to the same earth rod as the solar array if a separate earth connection is not available.

16. Advice on Surge Protection

The refrigerator has surge protection fitted (varistors) to protect the electrical circuits of the refrigerator. These are located at the rear of the refrigerator underneath the solar array connection point (see page 36). Please disconnect the solar array before accessing the varistors (trained technician only).

The electrical characteristics of varistors vary widely. Only use spares supplied by Dulas to ensure that the correct part is installed.

17. Solar Array Earthing

In order to provide electrical bonding for the metal parts of the solar array an earthing kit has been provided as part of this system.

Find a good location close to the building where the full length of the earth rod can be completely sunk into the ground, within easy reach of the earth cable. Run the earth cable in the shortest and straightest route from the solar array to the earth rod, ensuring it is securely attached to the building and / or support structure.

Using the clamp supplied connect the earth rod to one end of the earth cable and connect the solar array and mounting system to the other end using the fittings provided.

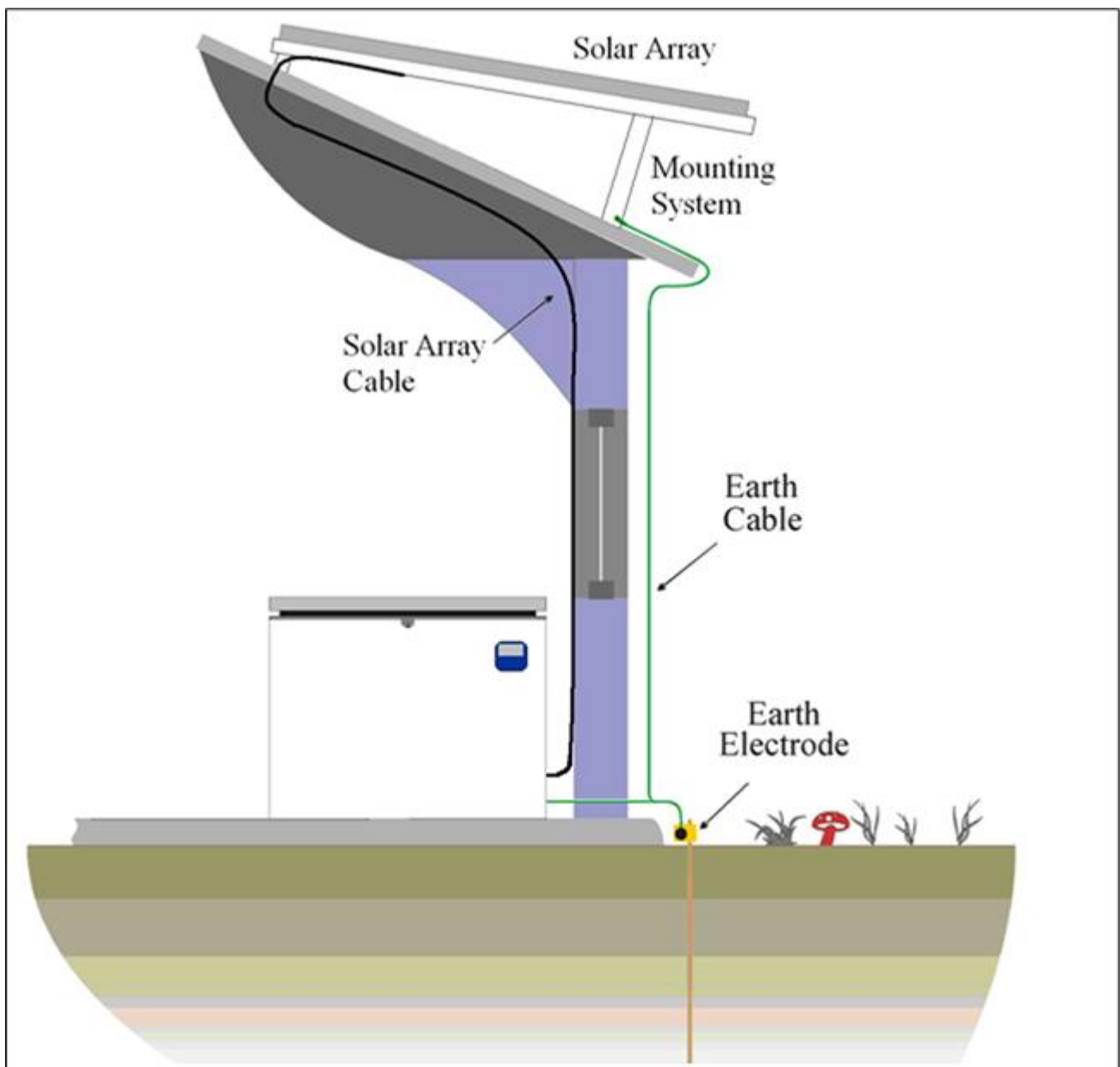

18. Refrigerator Installation

DO NOT position the refrigerator in direct sunlight or next to any heat sources. Make sure the refrigerator is positioned to provide good ventilation and ease of access for maintenance. Ventilation is particularly important for the condensers and compressors.

- 1) Position the refrigerator on a level surface; wipe all internal and external surfaces with a clean cloth.
- 2) Check the PV isolator at the back of the cabinet is in the '0' position.
- 3) Plug the solar connectors into the refrigerator. Check that there is sufficient slack in the cable to allow access to the back of the refrigerator.
- 4) Turn the PV isolator on by switching it to "1". Within 1 minute the compressor will start if there is sufficient sunlight (solar irradiance of $>125\text{W/m}^2$). You will be able to hear the compressor operating and feel the condensers getting warm.
- 5) Check that the refrigerator compartment temperature display on the front of the cabinet is operating. If there is insufficient natural light shine a torch on the display for a few seconds.



- 6) Ensure that all baskets are in position and the refrigerator lid is firmly closed.
- 7) Check that all cables are securely supported so that they will not be pulled loose if the refrigerator is moved for cleaning.
- 8) Roll the refrigerator into its final position and apply the brakes on the castors to secure it.

19. System Commissioning

- Complete the Installation & Commissioning record at the end of this manual (Section 24) and ensure all manuals are stored close to the refrigerator for ease of reference.
- Connect the solar panels and allow the refrigerator to run for at least 7 days.
- Periodically check the solar array between sunrise and sunset during the first few days of operation to ensure that there is no chance of any shading. If it looks like shading may become a problem later on (i.e. when the sun is lower in the sky) move the solar array to a better location adjusting the solar and earth cable accordingly.
- When the refrigerator compartment temperature display reads +4.5°C or less by 4pm in the afternoon, then the cold store is sufficiently charged (this may take a few days depending on the level of sunshine).
- Follow our instructions for loading vaccines in Section 19 below. **Only store vaccines in the refrigerator.**
- Leaving space for air circulation around the contents of the refrigerator will help to stabilise temperatures quicker and maintain an even temperature throughout the compartment.
- Keep the lid closed at all times, open only when required and lock after use.
- Ensure the users understand the basic functions of the refrigerator and that they are also aware of the correct operational procedures and maintenance tasks for this refrigerator.

20. Refrigerator Loading

IN ORDER TO KEEP INTERNAL TEMPERATURES OPTIMISED AND MINIMISE ENERGY CONSUMPTION, ONLY OPEN THE LID WHEN STRICTLY NECESSARY.

The VC88SDD refrigerator has a single compartment specifically for the storage of vaccines, see Section 4. The refrigerator compartment is designed to maintain a stable temperature between +2°C and +8°C across an ambient temperature range from +5°C to +43°C . There are no points within the vaccine compartment that drop below freezing and thus no danger of freezing vaccines.

The refrigerator contains stacking baskets designed to make stock management easier and encourage air circulation within the compartment.

Do not remove these baskets and do not store vaccines outside of these baskets.

The wire baskets encourage the circulation of air by maintaining a small gap between the basket and the cabinet wall. Good air circulation will help the refrigerator to maintain an even temperature throughout the compartment. In order to save energy, try to keep the lid open for as short a time as possible.

Stock management

- Allocate a certain space for each different type of vaccine, so that they may be located rapidly.
- Check the vaccine labels and adhere to any special requirements.
- Always use before expiry date (store older vaccines on top).
- Store the most frequently used vaccines in the top baskets for easy access.

WARNING: ALWAYS FOLLOW THESE VACCINE STORAGE GUIDELINES

21. Green compressor status LED light

The green LED light on the front of the refrigerator illuminates to indicate that the compressor is operating. The compressor will run if the refrigerator temperature is above about 4 degrees and there is sufficient solar power.

Normal operation

The refrigerator warms up slightly overnight. It is usual for the compressor to start running shortly after sunrise. It will run continuously for a few hours to cool the refrigerator. After this time the compressor will begin cycling on and off to maintain the correct internal temperature. This will continue until the sun sets at the end of the day. At night there is no power to the refrigerator and so the compressor will not run nor will the LED light operate.

22. User Training

The end user of the VC88SDD should be instructed in the simple processes outlined below and also those in Section 22. It should be stressed that these tasks are essential to ensure correct and reliable operation of the refrigerator.

Caution: failure to follow these instructions may lead to system failure and vaccine wastage.

If you have a problem, please contact your appointed engineer.

When turning on for the first time or when the refrigerator has been turned off for more than 3 days:

- Connect the solar panels and allow the refrigerator to run for at least 7 days.
- Before loading with vaccines, ensure that the temperature display on the front of the refrigerator reads +4.5°C or less by 4pm in the afternoon.

Daily Routine

- Keep the lid closed, open only when required and lock after use.
- Store the most frequently used vaccines in the top baskets for easy access.
- Do not keep food or drink in the refrigerator.

Vaccine Storage:

- Only store vaccines in the refrigerator.
- Use the baskets provided: Do not store vaccines outside the baskets.
- Always store vaccine in its original packaging.
- Always keep the same type of vaccine together and store your vaccine neatly.
- Always use old vaccines before new ones; before use make sure the vaccine has not expired.

23. Maintenance Tasks

Every morning and afternoon:

- Check the temperature
- Fill in the daily record sheet

On the first day of every week:

- Wipe away any moisture build up around cabinet lid
- Clean the solar array

On the first day of every month:

- Clean the refrigerator, condensers and compressors and drain any water from the bottom of the cabinet using the inbuilt drain
- Check the solar array is not shaded between 7am and 5pm

Every 6 months:

- Check all mechanical fixings and electrical connections (including the array)

24. Troubleshooting Guide

Section 1 General description

The VC88SDD is based on well proven technology and components and should prove to be very reliable in operation. However if there is a fault it has been designed for easy access to the main components. The picture below shows the location of the major refrigeration components once the rear cover is removed.

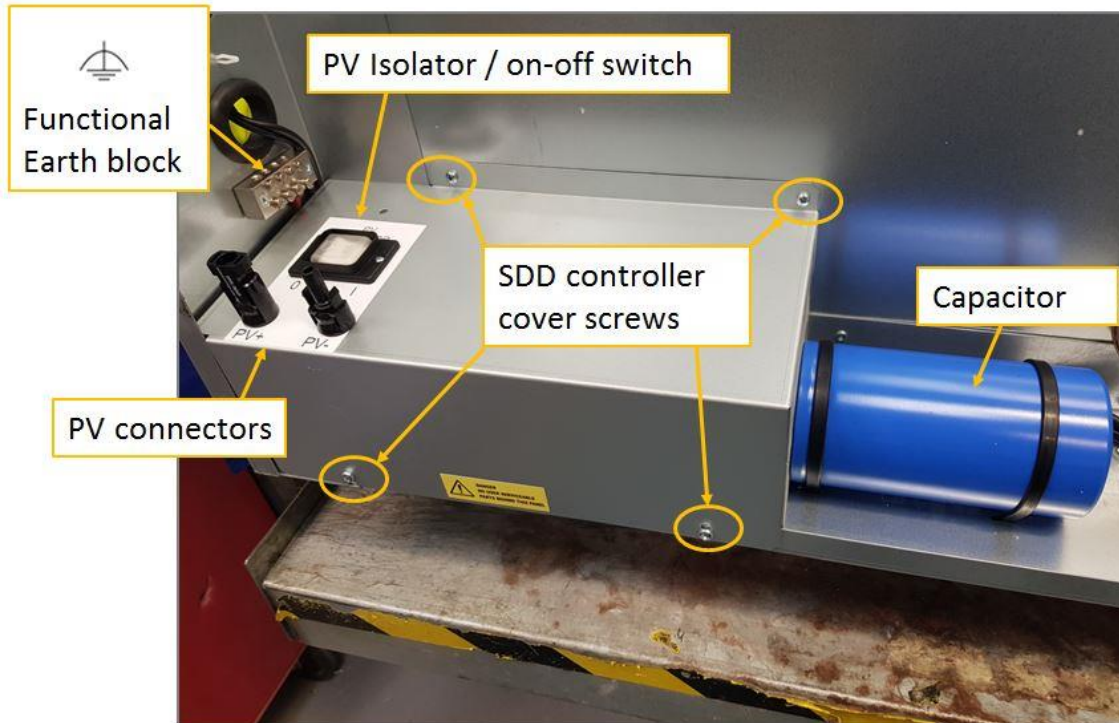

Description of components on the wiring diagram

(Refer to Section 25. VC88SDD Electrical Schematic)

All wires lead to the SDD control board, so power from the PV flows through the control to the compressor, capacitor etc.

The capacitor provides a short term energy store to keep the compressor running during brief reductions in light intensity. It's also required for starting of the compressor. There is a "bleed" resistor connected in parallel with the capacitor to ensure that it discharges when the PV is disconnected. However this takes some time: **wait one minute after power has been removed.**

The switch / circuit breaker marked on FU1 the diagram provides over current protection and PV isolation. It should always be turned off during connection and disconnection of the PV array, and whilst working on the circuit wiring.

The Dulas Lightning Protection Board is intended to protect the refrigerator from high voltages caused by lightning strikes. It is not a substitute for proper earthing of the PV module frames.

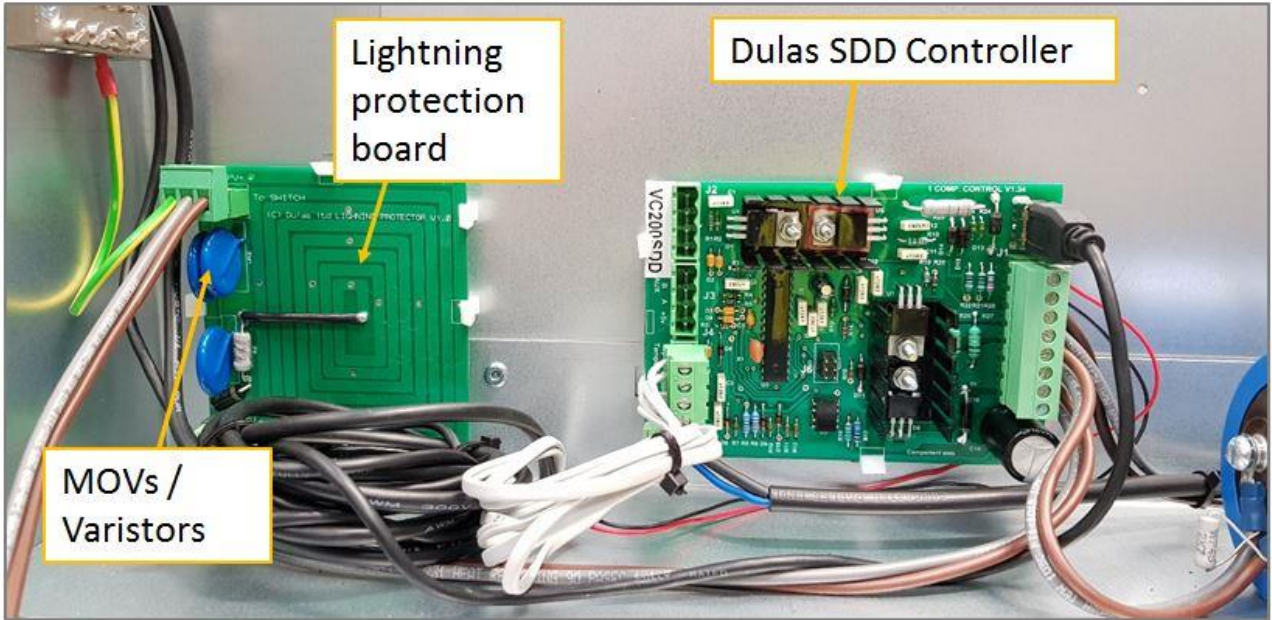

Section 2. How to check that the Dulas PV array is working

1. Switch the PV isolator off (indicated by a “0”)
2. Disconnect the PV cables from the refrigerator.
3. Connect the supplied test leads to a suitable multimeter as shown in photograph.
4. Connect the PV cables to the test leads.
5. Measure the PV array open circuit voltage. This should be more than 24V but less than 45V.
6. Measure the PV array short circuit current. This will depend on the light level on the array. In bright sun each module will produce up to 9A of current. Two modules will produce 18A and so forth (Even in low light the short circuit current should be more than a few amps.)

Caution: Make sure that the current rating of the meter can withstand the likely current. The current measurement should be made quickly and the wires disconnected to prevent the meter from overheating.

The compressor will need a current of at least 2A to start.

7. When checking is complete and the array is working correctly disconnect the PV cables from the meter and reconnect them to the refrigerator.

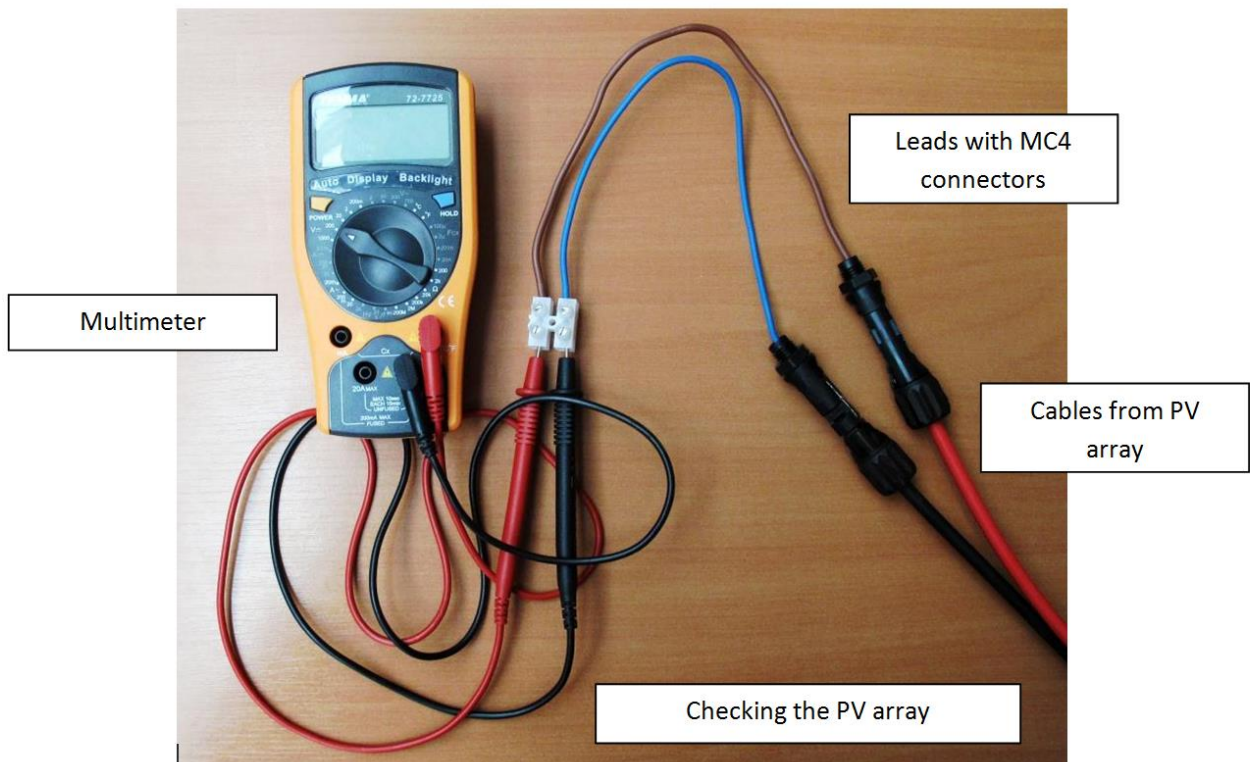

Section 3. How to check that the compressor is working

The Secop compressor and compressor controllers are a well-established design and are very robust.

Note: Terminology in this procedure refers to the diagram on the following page and also Section 25. VC88SDD Electrical Schematic

Before testing the compressor confirm that the PV array is working – see Section 2.

To test the compressor and compressor controller it can be directly connected to the PV as follows, be sure to have confirmed that the PV array is working first:

1. Switch the PV isolator off (indicated by a “0”).
2. Remove the four screws that secure the Dulas SDD controller cover and lift off cover.
3. Make a note of the connections to connector J1 so that they can be reconnected correctly after completing the test.
4. Disconnect connector J1. Remove the two PV cables. Switch the PV isolator on (indicated by a “1”). Check the open circuit voltage and short circuit current of the PV array.
5. Temporarily connect the PV cables to the compressor cables and capacitor cables. The circuit board has labels by the connector.

PV+ cable should be connected to +COMP cable and +CAP cable. These three cables should be the same colour.

PV- cable should be connected to COMP- cable and CAP- cable. These three cables should be the same colour.

6. Disconnect connector J5; make a short circuit between the two wires leading to the compressor.
7. Switch the PV isolator on. Check that the compressor is running. After running for a few minutes the condensers should both start to get warm.
8. If the compressor runs and after ten minutes the condensers get warm it can be assumed the compressor, compressor controller and refrigeration circuit are working.
9. Switch off the PV at the isolating switch. Now replace the connections to their original condition:

Remove the short on the J5 connector and reconnect it to the circuit board.

Reconnect the PV, capacitor, and refrigerator cables to the J1 connector and reconnect to the circuit board.

10. If the PV array is working and the compressor is working go to the next section to test the Dulas SDD controller.

Section 4. Dulas SDD controller testing.

If Section 2 and Section 3 have been completed and no problem has been found the problem is likely to lie with the Dulas SDD controller. This controller provides the following:

- **Connections for the compressor, PV and capacitor (connector J1).**

- **The refrigerator thermostat**

There are two temperature sensors mounted on the right hand side at the top and bottom of the vaccine storage compartment. When there is sufficient light for the PV array to allow the compressor to run the Dulas SDD controller ensures that the average of these two temperature sensors is maintained at 3.7C. As a fail-safe the compressor will turn off if the lower temperature is below 3C, even if the average temperature is higher than 3.7C.

- **Control of the green LED on the front panel**

The front panel LED will illuminate to signify that the compressor is running.

If there is enough solar power the compressor will usually run for a few hours at the start of the day and then run intermittently after that to maintain the correct internal temperature.

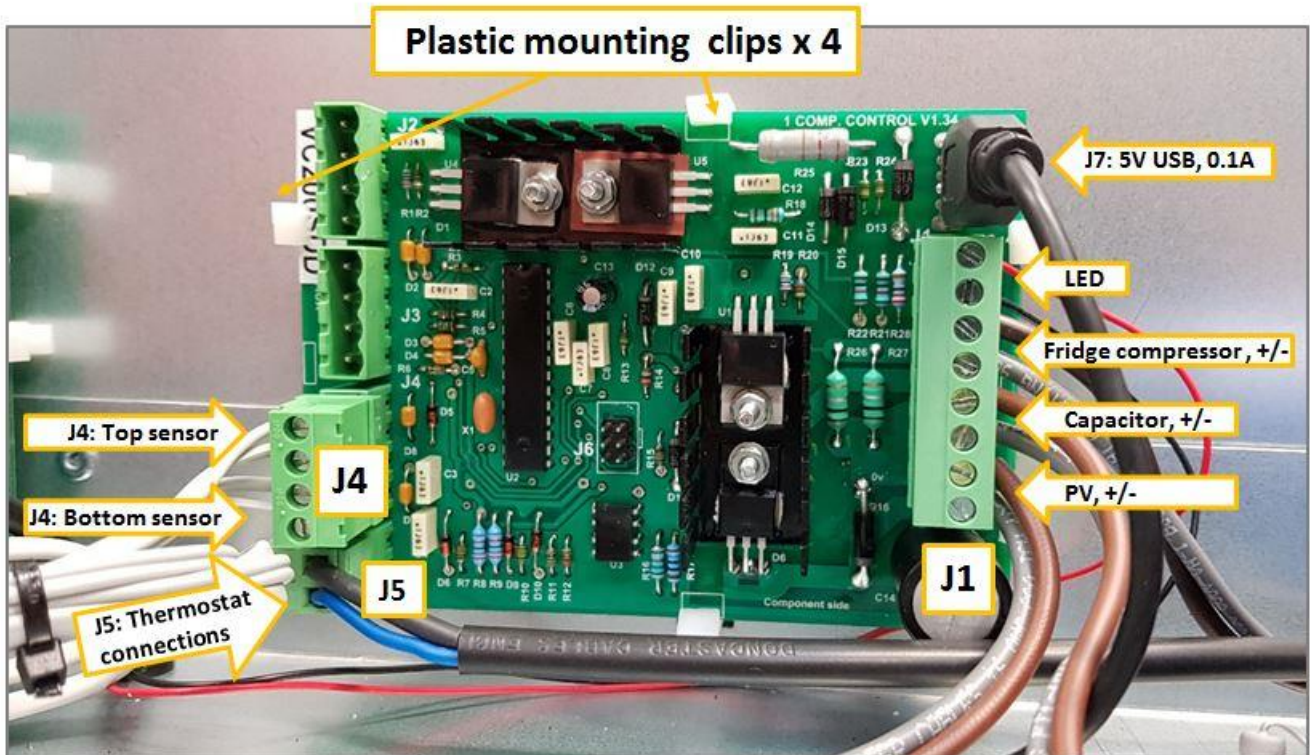

The following checklist should be used to check that the controller is working. If any of the tests fail the controller should be replaced.

	Test	What to do if the test fails
1	<p>Check that the controller passes power to the compressor and capacitor: Measure the PV voltage on connector J1. Measure the voltage on the capacitor and compressor power terminals on J1. These two should be no less than 0.5V smaller than the PV voltage.</p>	Replace the controller
2	<p>Check that the controller is basically working: Once the PV and compressor have been checked. (Section 2 and 3). Normal operation of the control circuit can be assessed:</p> <p>Connect the PV and switch on. Open the refrigerator lid, remove the basket and warm the temperature sensors with your hand. Check that the compressor has started and the Green LED on the front of the refrigerator is ON. Temporarily disconnect J5. The compressor should stop and the LED should be OFF.</p>	Replace the control board.
3	<p>Check that the thermostat is set to the correct temperature: There is no adjustment of the thermostat temperature but it can be checked as follows:</p> <p>Run the refrigerator and wait until the compressor stops running. Don't open the cabinet lid. The temperature on the display on the front of the refrigerator should be between 2.5 and 4.0C.</p>	<p>The thermostat has been factory set to ensure the correct operation of the refrigerator over a very wide range of operating conditions.</p> <p>If the compressor is not being turned on or off at the right temperature the control board should be replaced.</p>

Replacing the Dulas SDD controller

Switch the PV isolator off and disconnect the PV cables. Make a note of the orientation of the SDD controller. Unplug the connectors to the circuit board and prise back the white plastic clips on each edge of the board to release it from the refrigerator chassis.

Install the replacement board with the same orientation. Plug in the cables to the controller, reconnect the PV and switch on. If the refrigerator is working replace the metal cover over the controller.

Section 5 – Checking the Dulas Lightning Protection board

The Dulas Lightning Protection board incorporates three Metal Oxide Varistors (MOVs) lightning protection devices on the board. These will absorb the small lightning strikes that may occur nearby to the installation but will not be effective against large lightning strikes. If the MOVs are damaged in the event of a large strike they will fail and must the board must be replaced.

To check if the board is still effective conduct the following test:

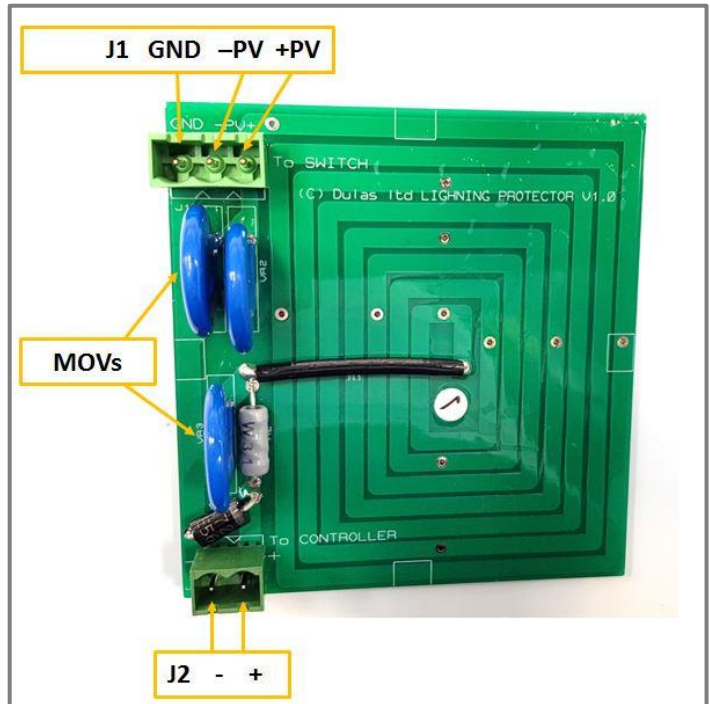

1. Switch the PV isolator to “0”.
2. Wait two minutes or more to ensure the capacitor has discharged and then remove the controller cover.
3. Disconnect the mating connectors from J1 and J2.
4. Ease the 4 plastic clips securing the circuit board to one side and remove the circuit board.
5. Visually check both sides of the board for signs of damage or discolouration.
6. Use a multi-meter set to the lowest resistance range to measure the resistance from connection J1/ PV+ to J2/ +. This should be less than 0.15 ohms. It is sometimes necessary to measure the resistance of the multimeter leads shorted together and subtract this “zero” reading from the measured resistance of the circuit board.
7. Use a multi-meter set to the lowest resistance range to measure the resistance from connection J1/ -PV to J2/ -. This should be less than 0.1 ohms. It is sometimes necessary to measure the resistance of the multimeter leads shorted together and subtract this “zero” reading from the measured resistance of the circuit board.
8. Use a multimeter set to its highest resistance range to measure the resistance between J2 /+ and J2/ -. This should be greater than 1M ohm. Be careful to ensure that you are not touching the connections as the reading is being taken as this will lower the measured resistance.

If all the above tests are satisfactory the board can be re-installed. If any tests fail a replacement board should be installed.

25. Installation & Commissioning Record

Site name and location:

Date:

Name of person responsible for installation:.....

Name of person responsible for health centre:

1. Before Going to Site

Please or
insert value.

• Check your toolkit.	
• Check you have appropriate fixings.	
• Check you have appropriate spare parts.	
• Check the equipment is OK.	

2. Site Inspection and Planning

STOP AND THINK

• Select a suitable location for the refrigerator.	
• Select a suitable location for the solar array: Check for orientation – should be towards equator, Check for shading between 7am and 5pm, Check for ease of access (for installation and cleaning), Check for length of cable to refrigerator.	
• You may need to negotiate with the user.	
• You may need to re-think the refrigerator location if the solar array location is difficult.	
• Stop and think of other options before starting the installation work.	
• Make a sketch of the site showing the main features, and including a plan of the rooms.	

3. Solar Array Installation

<u>WORKING AT HEIGHT IS DANGEROUS – PLEASE OBSERVE ALL REASONABLE SAFETY PRECAUTIONS</u>	
<ul style="list-style-type: none"> Record the direction of the solar array: degrees. 	
<ul style="list-style-type: none"> Record the tilt angle of the solar array: degrees. 	
<ul style="list-style-type: none"> Check there is no possibility of shading between 7am and 5pm. 	
<ul style="list-style-type: none"> Check each solar module for mechanical damage. 	
<ul style="list-style-type: none"> Record the serial number, open circuit voltage and short circuit current for each solar module below: 	

Solar Module	Serial Number	Voc	Isc
1			
2			

<ul style="list-style-type: none"> Assemble the array frame and attach the solar modules. Check each solar module is securely fixed. 	
<ul style="list-style-type: none"> Complete solar module interconnection wiring and connect solar cable. Check that the connections are tight. 	
<ul style="list-style-type: none"> Measure and record Voc of the solar array: Voc = 	
<ul style="list-style-type: none"> Check that array Voc is similar to the Voc for individual modules 	
<ul style="list-style-type: none"> Measure and record Isc of the solar array: Isc = 	
<ul style="list-style-type: none"> Check that array Isc is similar to the sum of the Isc for the individual modules 	
<ul style="list-style-type: none"> Install the assembled solar array on the roof. 	
<ul style="list-style-type: none"> Route the solar cable to the refrigerator location and fix securely. 	
<ul style="list-style-type: none"> Install the array earthing as close to the solar array as possible, ensuring the earth cable is installed at least 1.5m away from the solar cable. 	
<ul style="list-style-type: none"> Connect the earth cable to the array frame and to the earth rod then secure the earth cable. The earth cable should follow the shortest and straightest possible path between the frame and the rod. 	

4. Refrigerator Installation and Commissioning

<ul style="list-style-type: none"> • Make sure there is enough cable for the refrigerator to be moved for maintenance and cleaning. 	
<ul style="list-style-type: none"> • Ensure that the PV switch on the refrigerator is in the 'OFF' position. 	
<ul style="list-style-type: none"> • Connect the cable to the refrigerator and turn the PV switch 'ON'. 	
<ul style="list-style-type: none"> • Very firmly secure the solar cable to the wall, ensuring that if it is pulled it cannot strain the electrical connections. 	
<ul style="list-style-type: none"> • Check the refrigerator compartment temperature display for operation. Use a torch if natural light is insufficient. 	
<ul style="list-style-type: none"> • Check the refrigerator cooling circuit is working (condensers should get warm). 	
<ul style="list-style-type: none"> • Allow the temperature to stabilise (this may take up to 7 days) 	
<ul style="list-style-type: none"> • Check that the refrigerator compartment is +4°C to +6°C 	

5. Finally...

STOP AND THINK

Have we done a good job?
Is it good quality?

<ul style="list-style-type: none"> • Check that all cables are securely fixed and terminated 	
<ul style="list-style-type: none"> • Complete the user training. Make sure the user understands: How to get help, How to operate the system, How to do routine maintenance. 	
<ul style="list-style-type: none"> • Tidy up the site making sure nothing is left behind. 	
<ul style="list-style-type: none"> • Check that the installation record is complete and signed by the responsible persons. 	

Signature of person responsible for installation

Signature of person responsible for health centre.....

26. VC88SDD Electrical Schematic

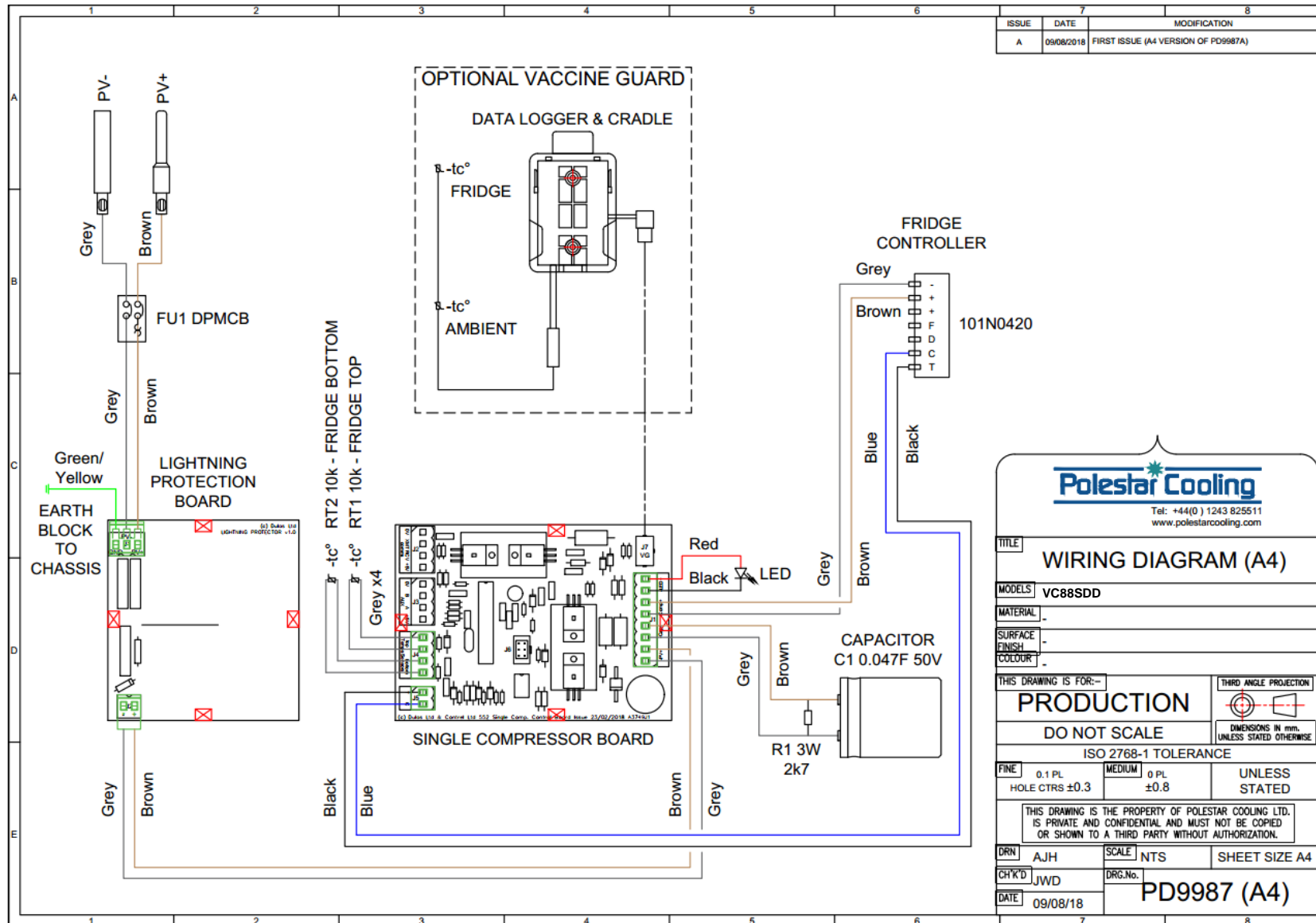

27. VC88SDD Refrigeration Schematic

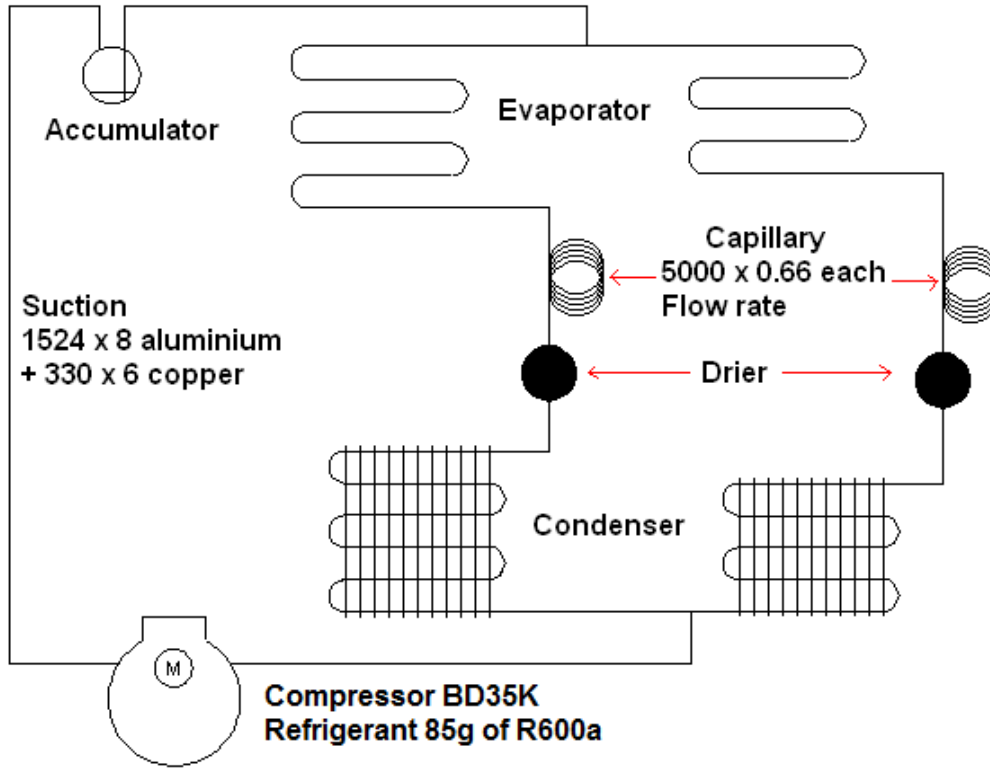

28. Spare parts

Listed below are the most likely spare parts required by the VC88SDD over the course of its lifetime. It is recommended that one set of these spares is purchased for every 10 refrigerators.

Spare Part Description	Spare Part No.	Stocking Rate (n/100)
Dulas SDD controller	SDD CONTROLLER	10
Temp probe	SN4B15P1	10
Compressor controller	101N0420	10
MCB Fridge	693-CBTWF060C0	10
Lightning board	5541	10
Compressor BD35K	101Z0211	5
Solar Thermometer	56SD	5
Gasket Outer	PD9915	5
Gasket Inner	PD9916	5

Any other parts required can be obtained by contacting Dulas on the details at the end of this manual.

29. VC88SDD System Layout





For more information contact:

DULAS Ltd, Dyfi Eco Park, Machynlleth, Powys, SY20 8AX, UK

tel: +44(0)1654 705055 fax: +44(0)1654 703000

email: solar@dulas.org.uk

website: www.dulassolar.org